



General Description

The ELFT3 curved ribbed center troffer luminaire component kit is an unwired LED fixture kit that features a luminous LED diffuser highlighted by a curved center ribbed design detail. It leverages A.L.P.'s proven, durable 2'x2' EL housings and door frame for performance and versatility. A new, low profile external ballast cover improves performance and efficiency.

Features and Benefits

- Available in standard 2'x2' size
- Driver is mounted outside the fixture cavity in a spec grade driver box with multiple wiring entry points
- Complete access to the driver compartment is available from the floor side of the installed unit
- Designed for use with Emitter LED boards (not provided)

Applications

For use in commercial applications such as offices, schools, lobbies and any space which utilizes grid ceiling systems and uses troffers for illumination.

Ordering Information

Please call 877-257-5841 for price and delivery.

ELFT3 Curved Ribbed Center Troffer Luminaire Component Kit

A revolutionary uniformly luminous, evenly diffused component set to produce a specification grade troffer luminaire with visual sculpture and depth.

Diffuser

2'x2' constructed with proprietary blend of LED acrylic and impact acrylic resins.

Light transmission

Approximately 75% with excellent pixel hiding power. Custom Formulations with higher Light Transmission and higher pixel hiding power available upon request.

Housing

3-3/4" deep. Die-formed 23-gauge steel.

Ends

Snap into housing or can be secured with #8 x 3/8" screw or 1/8" pop rivet with 1/8" to 3/16" grip (not included).

Driver Box

Mounted outside the fixture and access to the driver compartment is available from the floor side of the installed unit.

Housing Finish

White polyester polymer with a minimum 82% reflectivity.

ELFT3 Curved Ribbed Center Troffer Luminaire Component Kit

Diffuser Dimensions

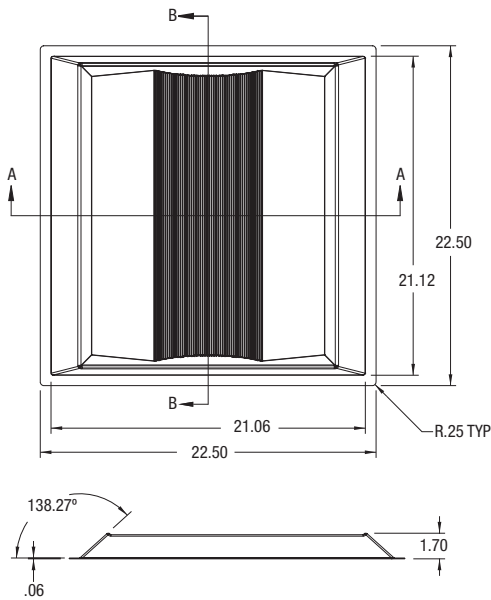

RLR FT3 Curved Ribbed Center Troffer Diffuser

Diffuser Part Number	Description	Size
FT3-22-S84-ALP	2'x2' curved ribbed center troffer diffuser to fit A.L.P. EL housing	2x2

EL Housings and Door Frame

Kit Part Number	Description	Size
EL-2x2-FTC	2'x2' A.L.P. EL housing with clean or "flat" body for LED modules	2x2

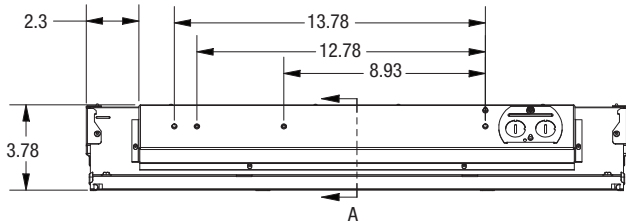
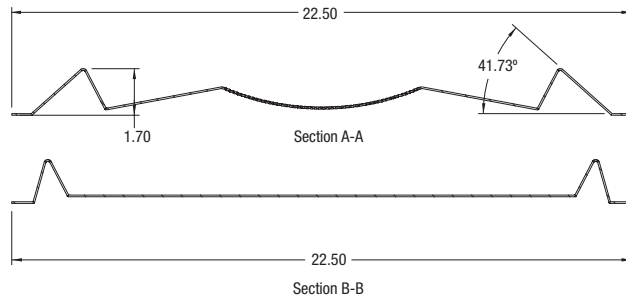

End Profile with Driver Box

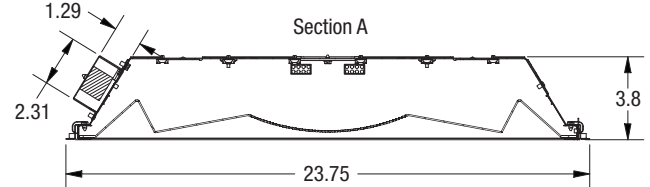

Sample

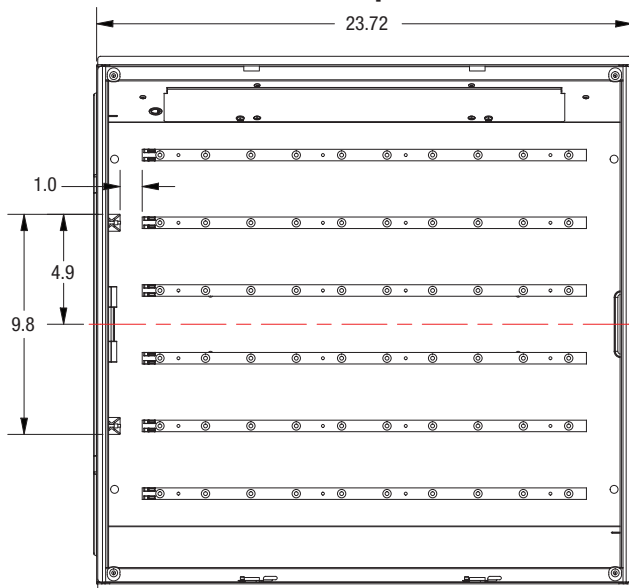

Wiring Diagram

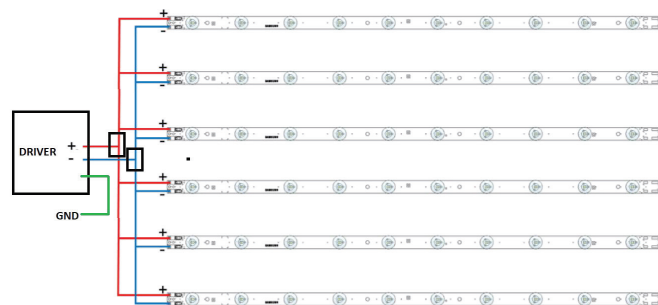

Notice

Dimensions subject to change without notice. This product is an OEM component kit requiring final assembly by a qualified OEM fixture manufacturer.

A.L.P.
6333 Gross Point Road, Niles, IL 60714

Ph: (877) 257-5841 • Fx: (773) 774-9331
www.alpadvantage.com

Represented by:
Ph. 800.621.1348



EL FT3 VN040522